

VELOSIT® WP120

HIGHLY FLEXIBLE CEMENTITIOUS WATERPROOFING SLURRY

Product Description

VELOSIT WP 120 is a polymer modified cementitious waterproofing slurry for concrete and masonry. It is a good substrate for coatings and overlays. It is crack bridging and a good barrier against carbon dioxide. VELOSIT WP 120 is a highly flexible cementitious waterproofing slurry with quick curing. VELOSIT WP 120 creates a crack bridging and abrasion resistant coating on the substrate. VELOSITWP 120 is the result of many years in the field testing and research.

Typical Applications

Waterproofing of:

- Basements and below grade
- Potable water structures
- Concrete podiums, balconies, decks
- Concrete retaining walls, planters
- Tanks for manure and sewage
- Swimming pools
- Green roofs
- Prefabricated garage roofs
- underneath tiles and natural stones

Properties

- Approved by AWQC - AS/NZS 4020:2018
- Crack bridging
- Highly flexible, tensile elongation > 100 %
- Easy to apply
- Resists 50 m water pressure acc. to EN 12390-8
- Low VOC
- Good resistance against aggressive media with a pH range of 3 – 12 and against soft water with low ion content
- Open to foot traffic after 3 – 4 hours (23 °C/60 % r.h.)
- Very good adhesion to concrete and masonry
- Final strength is achieved within 5 – 7 days
- Ready for water pressure after 5 days
- Fast air release with minimal requirement for agitation

Technical data

Colour	Grey	Water impermeability acc. EN 12390-B	Positive side: 5 bar Negative side: 1.5 bar
Mixing ratio by weight	100 : 50	Tensile strength	1.2 MPa (174 psi)
Mixing ratio by volume	100 : 65	Tensile elongation	105%
Density A-Component.	1.6kg/L	S _D -value _{water} : 2mm	2.5 m
Substrate temperature	5 – 35 °C	S _D -value CO ₂ : 2mm	230 m
Crack bridging	Acc. DIN 28052-6: 0.4 mm / 24h Acc. ASTM C836: 2.8 mm	Chloride ions	< 0.05%
Capillary water absorption	0.1 kg/m ² x h ^{0.5}	Adhesive strength	1.1 MPa
Carbonation resistance	passed		



VELOSIT® WP120

HIGHLY FLEXIBLE CEMENTITIOUS WATERPROOFING SLURRY

APPLICATION GUIDELINES

Surface Preparation

VELOSIT WP 120 is designed for mineralic substrates like concrete, masonry or absorptive natural stones. Substrate must be prepared with sand blasting, shot blasting or ideally high pressure water blasting (> 100 bar) to remove all bond breaking substances. Substrate must be pore open and load bearing. The minimum requirement for adhesive strength is 1.5 MPa (218 psi) and for the compressive strength 25 MPa. Lower strength values can be accepted if lower adhesive strength is acceptable. Active water leaks must be treated and fully stopped with VELOSIT PC 222. Leaking cracks need to be sealed with Hycem Spetec. Blowholes, honeycombs or other surface defects can be filled with VELOSIT WP 101 or the repair mortar VELOSIT RM 202. Before the application of VELOSIT WP 120, dampen the substrate with clean water to a saturated surface dry (SSD) condition.

Details

- A. Negative waterproofing:** In case hydrostatic pressure effects VELOSIT WP 120 or may effect in the future from the reverse side a negative side waterproofing must be applied with at least 1 mm VELOSIT WP 101.
- B. The wall-slab-detail** can be solved with a cove made with VELOSIT WP 101 and RM 202 or alternatively with a joint tape VELOSIT DB 830. The joint tape can be applied with VELOSIT WP 120.
- C. Joints and dynamic cracks** must be waterproofed with VELOSIT DB 830. The joint tape may be applied with or VELOSIT WP 120.
- D. Pipe penetrations** are waterproofed with a sleeve made from VELOSIT DB 830. Cut a hole into the sleeve with a diameter approx.6 mm smaller than the pipe. The sleeve is made from a 12 cm piece of VELOSIT DB 830. Brush plenty of VELOSIT WP 120 onto the pipe and the surrounding area. Pull the sleeve over the pipe push it with a trowel into the material. Work away from the pipe and take care not to entrap air or create wrinkles.

Mixing

Pour 2/3 the B-component of VELOSIT WP 120 into a suitable bucket and mix the powder with a slow speed drill (300 – 600 rpm) into the dispersion until a lump-free mix is achieved. Add the remaining B-comp. And additionally up to 1 l water under stirring to adjust the desired sistency. Water addition extends the cure time and should be kept as low as possible. The product is workable for 45 – 60 min. at 23 °C.

Brush application

Apply the first coat with a masons brush in a crossing applications to the pre-dampened substrate at the specified rate. Second coat can be applied after the first one has gained sufficient strength which is after 3 hours at 23 °C. Colder temperatures extend, warmer temperatures shorten this time.

Trowel application

If building code or specification does not require two coats, VELOSIT WP 120 can be applied in one coat by trowel. Make sure to adjust the consistency to a thixotropic workability without water addition. Apply a scratch coat of VELOSIT WP 120 to the damp substrate to fill surface irregularities. Immediately apply the desired material amount with a notched trowel to the substrate. 2 mm dry film thickness can be achieved with a 6 mm notch size and application at a 45° angle. Finish the surface immediately afterwards. Make sure all grooves are completely closed without air entrapment.

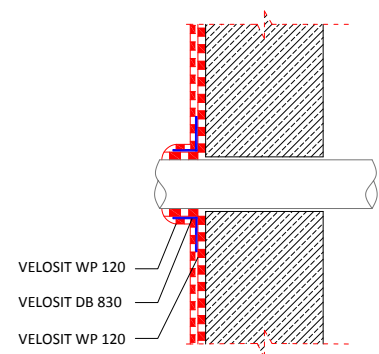
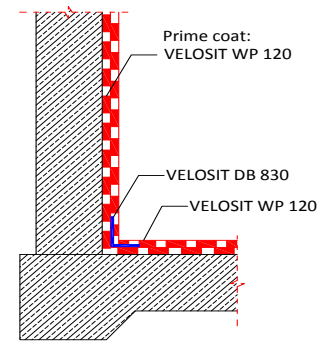



VELOSIT® WP120

HIGHLY FLEXIBLE CEMENTITIOUS WATERPROOFING SLURRY

Spray application

Use suitable spray machines such as:

- Inotec GmbH: INOMAT-M8
- HighTech GmbH: HighPump Small
- Desoi GmbH: Desoi SP-Y

Fill the product into the feed hopper of the spray machine and spray continuously. VELOSIT WP 120 can be applied in one lift if specification allows. Otherwise spray in two layers with a wait time of approx. 60 min. between coats. Long spray interruptions may result in clogging of the spray hose. The product may cure a lot faster if the hose is exposed to direct sunlight. Always empty and flush the machine after spraying or before long spray interruptions. VELOSIT WP 120 is a fast curing material and may be hard to remove if left in the machine.

Curing

VELOSIT WP 120 does not require long term curing as it reacts relatively fast with water from the B-component. Avoid direct sun light or wind or air flow after the application. Otherwise it is mandatory to work in two coats to avoid shrinkage cracks.

ESTIMATING

Brush application 2 mm:	1st coat VELOSIT WP 120: 1.7 kg/m ² 2nd coat VELOSIT WP 120: 1.7 kg/m ²
Trowel application 2 mm	Scratch coat VELOSIT WP 120: 0 – 0.5 kg/m ² 2nd coat VELOSIT WP 120: 2.9 – 3.4 kg/m ²
Spray application 2 mm:	VELOSIT WP 120: 3.4 kg/m ²

Other thickness requirements: 1.7 kg VELOSIT WP 120 per m² for 1 mm dry film thickness on smooth substrates. Depending on surface roughness application rates can be significantly higher.

Recommended thickness	
Dampproofing	1.25 mm
< 25 cm water	1.5 mm
Hydrostatic pressure	2.0 mm
Hydrostatic pressure and water flor or light mechanical abrasion	2.5 mm

Always observe building code or specification requirements!

CLEAN UP

VELOSIT WP 120 can be removed in the fresh state with water. Once it has cured mechanical cleaning is required.

PACKAGING

The A-component is available in 20 kg watertight plastic bags. The B-component is packages in 10L plastic pails.

STORAGE

In unopened original packs for 12 months at 5 – 35 °C in a dry storage place protected against sunlight.

SAFETY

Please observe the actual valid material safety data sheet and follow the described safety measures for handling of the product.





VELOSIT® WP120

HIGHLY FLEXIBLE CEMENTITIOUS WATERPROOFING SLURRY

Warranties and Disclaimers

Hychem warrants that this product shall conform to the technical specifications published in the product literature. The quality and fitness of the product is dependent upon the proper use and application of the product by the applicator. Hychem has no role in the application of the finished polymer other than to manufacture and supply its components. It is vital that the person applying this product understands the product and is fully trained and certified in the use of spray equipment and application of sol-gel materials. There are no warranties that extend beyond the description on the face of this instrument, except when provided in writing, directly by Hychem and executed under seal by a company officer.

Field Support

Field support where provided, does not constitute supervisory responsibility. Suggestions made by HYCHEM either verbally or in writing may be followed, modified or rejected by the owner, engineer or contractor since they and not HYCHEM are responsible for carrying out procedures appropriate to a specific application.

Customer Responsibility

The technical information and application advice given in this publication is based on the best information available at the time of print. As the information herein is of a general nature, no assumption can be made as to the product suitability for a particular use or application and no warranty as to its accuracy, reliability or completeness either expressed or implied is given other than those required by Commonwealth or State Legislation. The owner, his representative or the contractor is responsible for checking the suitability of products for their intended use.

